

DHI-ASGG520T

Tripod Turnstile



System Overview

The ASGG5 series tripod turnstile is an access control equipment fitted with an access controller, arm control module, alarm module, and more. It can form a comprehensive access control system if expanded with other devices, such as an IC card reader, fingerprint scanner, QR code reader, and face recognition module.

Scene

Applicable to residential areas, schools, government facilities, factories, industrial parks, office buildings, and more.

Technical Specification

Basic

Product Dimensions	1200 mm × 200 mm × 980 mm (47.24" × 7.87" × 38.58")
Casing	Cabinet Thickness SUS304 1.5 mm (0.06")
Arm Material	Stainless steel

Function

Anti-collision	Yes
Memory Mode	Yes
Anti-trailing	Yes
Sound and Light Prompt	Yes
People Counting	Yes
Alarm	Yes

Performance

Unlocking Duration	2–60 s (5 s by default)
MCBF	> 3,000,000
Passing Frequency	20–40 people/minute
Passage Width	600 mm (23.62")

- Anti-collision
- Adjustable unlock duration
- Locks the arms after the unlock duration
- Locks or unlocks the turnstile with a remote control (optional)
- Reset parameters using the configuration application
- Sound and light prompts and adjustable volume
- Supports memory mode
- Supports unlocking the arms when powered off
- MCBF > 3,000,000
- Turns to always open status when it receives a fire alarm
- Supports outputting alarm signals
- Supports 9 passing modes, including passing with identity verification, no passing, and free passing
- Integrates face recognition, fingerprint and QR code modules for various unlock methods

General

Net Weight	37 kg (81.57 lb)
Gross Weight	60 kg (132.28 lb)
Protection Grade	IPX4
Power Consumption	Standby ≤ 10 W; working: ≤ 40 W
Operating Temperature	–25 °C to +70 °C (–13 °F to +158 °F)
Operating Humidity	5%–93% (RH), non-condensing
Operating Environment	Indoor and outdoor

Ordering Information

Type	Model	Description
Tripod turnstile	DHI-ASGG520T	Tripod turnstile for outdoor use
Cabinet	DHI-ASGG500T	An empty cabinet for all necessary components to form a tripod turnstile

Dimensions (mm[inch])

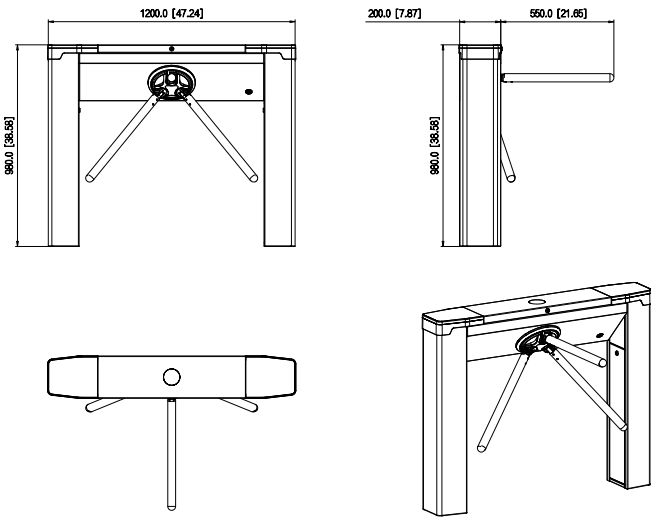

Application

